

**Final Technical Report  
TNW2000-03**

Research Project Agreement No. 509646-2  
Automated Bus Dispatching, Transit Control, and Transit **Service** Reliability, Phase Four

**Time Point-Level Analysis of Passenger  
Demand and Transit Service Reliability**

by

James **G.** Strathman

Thomas J. Kimpel

Kenneth J. Dueker

Center for Urban Studies  
College of Urban and Public Affairs  
Portland State University  
Portland, OR 97207

**Report prepared for:**  
**Transportation Northwest (TransNow)**  
Department of Civil Engineering  
129 More Hall  
University of Washington, Box 352700  
Seattle, WA 98195-2700

in cooperation with  
**U.S. Department of Transportation**  
Federal Highway Administration

July 2000

## TECHNICAL REPORT STANDARD TITLE PAGE

1. REPORT NO. <b>TNW2000-03</b>	2. GOVERNMENT ACCESSION NO.	3. RECIPIENT'S CATALOG NO.	
4. TITLE AND SUBTITLE <b>TIME POINT-LEVEL ANALYSIS OF PASSENGER DEMAND AND TRANSIT SERVICE RELIABILITY</b>		5. REPORT DATE <b>July 2000</b>	6. PERFORMING ORGANIZATION CODE
7. AUTHOR(S) <b>James Strathman, David Griffin, Richard L. Gerhart, Kenneth Turner</b>		8. PERFORMING ORGANIZATION REPORT NO. <b>TNW2000-03</b>	
9. PERFORMING ORGANIZATION NAME AND ADDRESS <b>Transportation Northwest Regional Center 10 (TransNow) Department of Civil Engineering 135 More Hall Box 352700 University of Washington Seattle, WA 98195-2700</b>		10. WORK UNIT NO.	
12. SPONSORING AGENCY NAME AND ADDRESS <b>United States Department of Transportation Office of the Secretary of Transportation 400 Seventh St. S.W. Washington, D.C. 20590</b>		11. CONTRACTOR GRANT NO. <b>DT0S88-G-0010</b>	
15. SUPPLEMENTARY NOTES <b>This study was conducted in cooperation with the University of Washington and Portland State University</b>		13. TYPE OF REPORT AND PERIOD COVERED <b>Final report</b>	
16. ABSTRACT <b>This paper provides a framework for analyzing transit service reliability and estimating passenger demand at the time point-level of analysis. It begins with a literature review of passenger demand modeling and transit service reliability analysis, and shows how advances in transportation technologies are producing vast amounts of data that encourage the use of new modeling techniques. Differences between route-level and time point-level demand modeling are discussed. Lastly, the results of the passenger demand and transit service reliability models estimated from Tri-Met BDS data are presented.</b>		14. SPONSORING AGENCY CODE	
17. KEY WORDS <b>computer-aided dispatch, CAD, automatic vehicle location, AVL, transit service reliability, operations control, transit demand, global positioning system, GPS, automatic passenger counter, APC</b>		18. DISTRIBUTION STATEMENT <b>No restrictions. This document is available to the public through the National Technical Information Service, Springfield, VA 22616</b>	
19. SECURITY CLASSIF. (of this report) <b>None</b>	20. SECURITY CLASSIF. (of this page) <b>None</b>	21. NO. OF PAGES <b>45</b>	22. PRICE <b>\$6.00</b>

## DISCLAIMER

The contents of this report reflect the views of the authors, who are responsible for the facts and the accuracy of the **data** presented herein. This document is disseminated through Transportation Northwest (**TransNow**) Regional Center under the sponsorship of the Department of Transportation UTC Grant Program in the interest of information exchange. The U.S. Government assumes no liability for the contents or use thereof. The contents do not necessarily reflect the views or policies of the U.S. Department of Transportation or **any** of the local sponsors.

## 1. Introduction

Considerable effort is being expended by transit agencies to implement advanced communications and transportation technologies capable of improving transit service reliability. Improvements in transit service reliability will produce benefits for both passengers and operators. Improved schedule adherence at bus stops will reduce the variability of bus arrival times and lower average passenger wait times. A decrease in arrival time variability will allow schedulers to remove excess running time built into schedules. This will free up resources for use elsewhere or negate the need for additional buses. Improved headway regularity will reduce bus bunching, lower average passenger wait times, and ensure that vehicle capacity is utilized efficiently. The primary issue is that there are monetary costs associated with unreliable service.

Unreliable service is caused by a number of factors that can be classified as either endogenous or exogenous to the transit system (Woodhull, 1987). Endogenous factors include passenger demand variation, route configuration, stop spacing, schedule accuracy, and driver behavior. Exogenous factors include traffic congestion and accidents, traffic signalization, on-street parking, and weather conditions. Recurring problems such as traffic congestion can be dealt with via scheduling. Nonrecurring problems such as vehicle breakdowns and traffic accidents add an additional level of complexity to the management of the system in real-time. Strategies to improve transit service reliability are typically classified as either short or long term strategies (Abkowitz, 1978; Turnquist 1978; Woodhull, 1987). Short term strategies involve returning service to schedule through operations control and include such actions as vehicle holding, short turning, leap frogging, and bringing additional vehicles into service. Long term strategies involve structural changes and include schedule modification, route reconfiguration, and driver training programs.

Transit patronage models provide a basis for transit planners to analyze the impacts of proposed service changes to assist in budget preparation and other resource allocation decisions. Service reliability is important to service planning in that it is related to the level of transit subsidy.

Transit systems with poor service quality require additional fiscal resources because of higher operating and capital costs. The amount of subsidy influences the budget which ultimately determines level of service (Tisato, 1998). Another justification for why transit service reliability is important to service planning is that unreliable service directly impacts passenger wait times. Bowman and Tumquist (1981) found that wait time at stops is much more sensitive to schedule reliability than service frequency. Increased wait times result in increased travel costs, which ultimately influence mode choice decisions. Routes characterized by unreliable service will likely suffer patronage declines over time. Transit service reliability is an important measure of service quality and directly affects both passenger demand and level of service.

Tri-Met, the transit provider for the Portland, Oregon metropolitan region, implemented an automated Bus Dispatch System (BDS) in the fall of 1996. BDS is based upon the integration of several technologies including: 1) an automatic vehicle location (AVL) system that uses global positioning system (GPS) technology to track buses in space and time; 2) a computer-aided dispatch (CAD) and control center; 3) a two-way radio system allowing voice and data communication between operators and dispatchers; and 4) automatic passenger counter (APC) technology. BDS collects data related to bus operations over the course of each day. Each time a stop or an event occurs, a data record describing bus location, passenger activity, or communication is stored on a removable data card connected to a computer located on each bus. **At** the end of each day, the data are transferred to a central computer where they are schedule matched and validated for accuracy. The data are ultimately stored in a relational database and used for a number of different purposes including performance monitoring, scheduling, and service planning.

This paper provides a framework for analyzing transit service reliability and estimating passenger demand at the time point-level of analysis. It begins with a literature review of passenger demand modeling and transit service reliability analysis, and shows how advances in transportation technologies are producing vast amounts of data that encourage the use of new modeling

techniques. Differences between route-level and time point-level demand modeling are discussed. Lastly, the results of the passenger demand and transit service reliability models estimated from Tri-Met BDS data are presented.

## **2. Transit Service Reliability**

Transit service reliability is a multidimensional phenomenon in that there is no single measure that can adequately address service quality. Departure delay (actual departure time minus scheduled departure time) effectively measures schedule adherence for a given bus at a particular location. Schedule adherence is an important reliability measure for **infrequent** users, timed transfers, and long headway service. Traditionally, transit agencies have used on-time performance (OTP) as a measure of schedule adherence. The majority of transit agencies define "on-time" as a bus arrival (departure) of no more than 1 minute early and 5 minutes late (Bates, 1986). OTP is a discrete measure that is particularly useful for evaluating system reliability from the perspective of the transit agency. OTP is typically expressed as the percentage of buses that depart a given location within a predetermined amount of time. The on-time window represents an acceptable range of delay tolerance that takes into account the fact that buses operate in a stochastic environment. In contrast, departure delay is a much better measure of performance from the perspective of the passenger. This is because passengers experience delay as continuous phenomena.

Headway delay (actual headway minus scheduled headway) effectively measures the relative spacing between buses. A negative value for headway delay means that a bus is falling behind its leader with a positive value meaning that a bus is gaining. Extreme variation in headway delay is associated with bus bunching.

Running time is also an important measure of transit performance. Running time represents the elapsed time it takes a bus to traverse from one location to another. Running time delay (actual running time minus scheduled running time) measures how well a bus is moving along each link.

A positive value of running time delay means that a bus is having **difficulty** traversing the link. Running time is an important measure of performance to operators because it serves as a key scheduling input and provides a way to monitor schedule accuracy. Running times are important to passengers to the extent that they affect in-vehicle travel time.

Attempts to improve service quality from the perspective of passengers should focus on reducing the variability of bus performance over time. If a bus is consistently 2 minutes late, passengers simply learn to time their arrival with that of the bus. If a bus departs 5 minutes late one day and 1 minute early the next, passengers are forced to arrive at stops much earlier in order to compensate for highly variable departure times. Transit agencies are typically interested in measuring bus performance over longer periods of time. For example, several months or a year's worth of operations data are typically summarized in route performance reports. Bus performance should be measured at intermediate locations along the route rather than at the route terminus because relatively few passengers are affected there (Woodhull, 1987; Henderson, Adkins, & Kwong, 1990; Nakanishi, 1997). For operators concerned with minimizing the negative effects of unreliable service, attention should be focused on improving service quality at locations where the greatest number of passengers are affected.

It is important to make a distinction between low and high frequency service when discussing transit service reliability. High frequency service is defined as bus service that operates at **headways** of 10 minutes or less (Oliver, 1971; Abkowitz & Engelstein, 1986; Abkowitz, Eiger, & Engelstein, 1986; Abkowitz & Tozzi, 1987). For routes characterized by infrequent service, schedule adherence is the most important reliability measure. Passengers attempt to time their arrivals with that of the bus based upon a given probability of missing the departure (Turnquist, 1978; Bowman and Tumquist, 1981). In these circumstances average wait times are less than one-half of the scheduled headway. Alternatively, for routes that operate at high frequencies, headway variability is the most important reliability indicator. The aggregate wait time of passengers is minimized when buses are evenly spaced. Because passengers do not find it

advantageous to time their arrivals with that of the schedule, an assumption of random passenger arrivals is valid

### **3. Literature Review**

Both transit service reliability and passenger demand vary over time, space, and by route typology (Abkowitz & Engelstein, 1983; Abkowitz & Engelstein, 1984; **Stopher**, 1992; Strathman & Hopper, 1993; Peng, 1994; Hartgen & Homer, 1997). The most important directional effect in demand occurs on radial routes during peak time periods. Passenger demand is greater in the inbound direction during the morning peak and lighter in the outbound direction. For the afternoon peak, demand is greater in the outbound direction. Transit **service** reliability also has a directional component, with performance generally declining to its lowest levels during the afternoon peak in the outbound direction. Route typology is important in that each route type serves a different function within the urban area. Radial routes are associated with high frequency service to and from downtown. They connect urban and suburban locations to the central business district (CBD). Radial routes may either be through routes or terminate in downtown. Cross-town routes serve trips between urban neighborhoods. A directional bias in demand does not usually exist for cross-town routes.

Surprisingly few econometric models have been developed analyzing the determinants of bus transit service reliability. The only econometric study known to explicitly address schedule adherence was a multinomial logit model developed by Strathman and Hopper (1993) that analyzed factors affecting the OTP of buses in Portland, Oregon. A discrete measure of OTP was used that defined "on-time" as a bus departing a time point no more than 1 minute early or 5 minutes later than scheduled. The model analyzed the relative probabilities of on-time/early, on-time/late, and early/late bus departures. Variables included the number of boardings and alightings, the number of stops since the previous time point, the position of the time point in the sequence of time points, distance since previous time point, scheduled headway, and dummy

variables consisting of weekday service, peak period service, part time driver, and new sign up period. The study found that the probability of a bus arriving on-time was adversely affected by the number of alighting passengers, scheduled headway, the time point in sequence of time points, part time driver, and new sign up period.

A number of investigators have noted that route characteristics are important determinants of transit service reliability (Tumquist, 1978; Woodhull, 1987; Abkowitz & Engelstein, 1984; Strathman & Hopper, 1993). The most common measures of route characteristics are scheduled distance and the number of scheduled stops. Bus performance tends to deteriorate with an increase in either one of these variables. At the route-segment level, cumulative measures from the route origin or from the previous time point may be used.

Several researchers have noted that driver experience and behavior are important factors affecting transit service reliability (Abkowitz, 1978; Woodhull, 1987; Levinson, 1991; Strathman & Hopper, 1993). Driver behaviors that may adversely affect bus performance include not departing from the terminal on time, making unscheduled stops, or spending excess dwell time at stops. Driver can positively influence bus performance by modifying bus speed and stopping activity in response to schedule adherence and bus spacing problems. No transit service reliability studies are known to exist that control for the effects of driver behavior on bus performance. An important aspect of the research by Strathman and Hopper is that they attempted to control for the effects of driver experience on bus performance. A dummy variable representing the first two weeks of a new sign up period was used to control for adjustments in behavior following changes in route assignments. A dummy variable representing part-time driver was also included because part-time drivers may either lack experience in general or be unfamiliar with a particular route.

Two empirical studies by Abkowitz and Engelstein examined factors affecting vehicle running times on two radial bus routes in Cincinnati, Ohio using ordinary least squares regression

techniques. Each route was divided into a series of 1-3 mile links. The first study sought to explain mean running time. The results showed that mean running time on individual links was affected by link distance, the number of boardings and alightings, the number of signalized intersections, the percentage of the link where peak period parking was allowed, and time period (Abkowitz & Engelstein, 1983; Abkowitz & Engelstein, 1984). Route-segment length was found to be the most important variable affecting mean running time followed by the number of signalized intersections and the number of boardings and alightings. The use of the two **traffic**-related variables is notable. Relatively few econometric studies have attempted to control for the effects of traffic conditions on bus performance, yet it is commonly believed to have an adverse effect on service reliability (Welding, 1957; **Sterman & Schofer, 1976**; Turnquist, 1982). Normal **traffic** conditions, including congestion, signalization, and the amount of time taken to merge back into traffic can be controlled for via scheduling. The most **important** traffic-related factor affecting bus performance is **non-recurring** traffic congestion. Schedules are designed to take into account a small degree of running time variation, yet it is not cost-effective for transit agencies to account for excess levels of congestion.

Passenger activity is widely believed to be a cause of unreliable service (Woodhull, 1987; Abkowitz & Engelstein, 1983; Abkowitz & Engelstein, 1984; Strathman & Hopper, 1993). According to Woodhull (1987), the effect of load variation on bus performance is largely a function of where the peak passenger load point is located. For inbound radial routes in the a.m. peak time period, the maximum load point is often located just outside the central business district (CBD). Bus performance is adversely affected by demand variation only over the last portion of the route. One would therefore expect delay variation to be less on radial peak inbound routes compared to radial peak outbound routes. For outbound radial routes during the afternoon peak time period, the maximum load point is often the CBD. The impact of demand variation on service reliability is important at downtown locations during the afternoon peak because headway delay variation at early points along a route will tend to propagate until bus bunching occurs.

The second running time model by Abkowitz and Engelstein addressed cumulative running time deviation. Cumulative running time deviation at the previous location was used to control for existing levels of **unreliability**. Route segment length and **running** time deviation at the previous location were shown to have adverse effects on cumulative running time deviation (Abkowitz & Engelstein, 1983). The authors also undertook an analysis of headway variation. Using data derived from a Monte Carlo simulation, the authors modeled the effects of running time variation and scheduled headway on headway variation. The study found that headway variation increases sharply near the beginning of a route, then reaches an upper bound (Abkowitz & Engelstein, 1984). According to the authors, the length of time taken to reach the upper bound is dependent upon the size of the scheduled headway and the amount of running time variation. This finding highlights the importance of controlling for the amount of scheduled service in analysis of transit service reliability because of its relationship to the amount of delay variation.

Random events such as such as traffic accidents and weather can adversely affect bus performance (Woodhull, 1987). The effects of weather are indirect in that they influence bus performance through traffic-related problems. Random events most likely to affect bus performance include those related to emergencies, mechanical failure, passenger behavior, traffic incidents, and driver-related problems. No transit service reliability studies are known to exist that have taken any of these sources of delay into account.

With the exception of the OTP model by Strathman and Hopper and the mean running time model by Abkowitz and Engelstein, the majority of transit service reliability models rely on rather simplistic model specifications. The reason for such a paucity of well-designed econometric models is primarily due to data limitations. Traditionally, manual data collection efforts proved to be costly, time consuming, and of limited duration. Advanced transportation and communications technologies, such as the Tri-Met BDS, now generate geographically detailed operations data on a continuous basis. This advance presents new opportunities for

analyzing transit service reliability in a more detailed and comprehensive manner than previously possible.

The general focus of previous passenger demand studies has been to model boardings as a function of level of service and a number of socioeconomic and demographic characteristics. With one exception, all models have been developed at the route-level. Similar to the early transit service reliability studies, many of the passenger demand studies suffer from data limitations. The passenger demand models developed by Peng (1994) represent the most advanced modeling efforts to date. Peng estimated a series of route-segment level models stratified by time of day and direction for bus routes in Portland, Oregon. Passenger demand was estimated as a function of transit service supply, population, downstream population, employment density, alightings from complimentary routes, ridership on competing routes, park-and-ride capacity, fare zone, and route typology. Service supply was estimated as a function of current ridership, previous year's ridership, population, employment density, and route typology. A third equation was included to control for the effects of competing routes on ridership. Competition between routes occurs where two or more routes that service the same destination have overlapping service areas. The results show that service supply, **population/employment**, income, and park and ride capacity are significant determinants of bus ridership. Route typology, fare zone, and inter-route effects were found to vary in importance between models. In the supply equation, current ridership, previous year's ridership, and **population/employment** were found to be important. The dummy variables for route typology also varied in significance between models. The most notable aspects of Peng's research were the development of route-segment level models and the use of simultaneous equations estimation to control feedback between supply, demand, and route competition.

Kemp (1981) also estimated a simultaneous equations model using pooled time **series/cross-sectional** data. Five structural equations were used, including two for demand (transferring and non-transferring passengers), two for supply (average headway and seat miles operated) and one

for bus performance (average bus speed). The demand equation for non-transferring passengers estimated passenger trips as a function of fare price, a proxy variable for auto travel costs, bus speed, wait time, hours of service, route length, stop spacing, number of school days, and other factors. The results showed that demand is negatively associated with fare price, stop spacing, route length, and various route dummies. Demand was found to be positively associated with service duration, the proxy variable for auto costs, number of school days, time trend, and various route dummies. Neither average bus speed nor average wait time was found to be significant in the demand equation. The study by Kemp is important in that it is the only known transit patronage model to incorporate aspects of service quality into the demand equation.

Most passenger demand models include measures related to service quantity (Kyte et al, 1988; Stopher, 1992; Peng, 1994; Hartgen & Homer, 1997). This is because passenger demand is related to the amount of transit service provided. This is particularly true at the route level of analysis where demand is directly related to the number of bus trips. At the route-segment level of analysis, this relationship is not nearly as pronounced. Allan and DiCesare (1978) argue that service quantity is characterized by the extent and breadth of service coverage, service frequency, and vehicle seating capacity. Seating capacity is important to demand modeling to the extent that two routes with different seating capacities operating at the same service frequency provide different levels of service. Service coverage is related to route typology and route characteristics.

All passenger demand models include one or more variables related to market size (Kyte et al, 1988; Stopher, 1992; Peng, 1994; Hartgen & Homer, 1997). The most common measures of market size are population and employment. These two variables are typically associated with transit service areas. Population is often included as an explanatory variable in all time periods except for the p.m. peak where employment is used instead. For off-peak time periods, it is common to use both population and employment since there is less of a directional bias in demand (Peng, 1994). It is also necessary to control for additional sources of patronage in passenger demand modeling. The most common sources of additional passengers include

transferring passengers (Kemp, 1981; Horowitz & Metzger, 1985; Peng, 1994), high school students (Kemp, 1981; Peng, 1994), and park and ride users (Peng, 1994). High school enrollment is relevant in the morning and midday time periods, although its impact on bus performance is likely to be greater in the midday time period. Transit centers are frequently associated with transfer points and park and ride lots. Transfers also occur at the intersection points of radial and cross-town routes.

A number of studies have shown that income is an important determinant of transit ridership (Algers, Hanson, & Tegner, 1975; Peng, 1994; Hartgen & Homer, 1997). Income is important variable in passenger demand modeling because it proxies for transit dependent riders. Peng used a variable related to the number of households with a median household income less than \$25,000. Other studies have shown that auto ownership has an adverse effect on transit ridership (Algers et al, 1975; Levinson & Brown-West, 1984). This is because the propensity to use transit decreases as accessibility to automobiles increases. Besides controlling for an income effect, most passenger demand studies have attempted to control for differences in fare price. Several studies have found that passenger demand is sensitive to transit fare price (Algers et al, 1975; Kemp, 1981; Kyte et al, 1988; Peng, 1994; Hartgen & Homer, 1997). Tri-Met operates a zonal fare structure system consisting of four fare zones. There exists little variation between a 2-zone fare (\$1.05) which is the basic minimum fare and an all zone fare (\$1.35). It is not likely that there is sufficient variation in this variable for it to be meaningful in the models developed in this study. The variable would also be subject to measurement error because many patrons uses transit passes and other forms of discounted fares.

A number of researchers have discussed problems resulting from data availability in passenger demand modeling (Kemp, 1981, Multisystems, Inc., 1982). Deficient data results in the specification of overly simplistic models or forces the use of crude proxy variables in place of more desirable measures. Several studies failed to address competition between routes, while others did not adequately allocate socioeconomic and demographic data to transit service areas.

With the exception of the analysis by Peng, no passenger demand studies have been developed below the route-level of analysis. It is evident that there exists feedback relationships between service supply, service quality, and demand and that simultaneous equations models are superior to ordinary least squares regression.

#### 4. Theoretical Models

The following section discusses the theoretical issues behind the development of route and time point-level transit service reliability and passenger demand models. The review of the existing literature suggests the following general models:

Demand =  $f(\text{service quantity, service quality, route characteristics, market size, income, fare price, other sources of ridership, route typology, time period, direction})$

Service quantity =  $f(\text{demand, service quality, route typology, time period, direction})$

Service quality =  $f(\text{demand, service quantity, route characteristics, driver behavior, random events, route typology, time period, direction})$

Previous researchers have addressed simultaneity between transit demand, supply, and route competition (Peng, 1994) and transit demand, supply, and service quality (Kemp, 1991). In a similar manner, simultaneity is expected to exist between service reliability (a measure of service quality), service supply, and passenger demand. As delay variability increases, more bus trips are required to serve the same number of passengers, yet as more bus trips are added, delay variability should decrease because there are upper bounds to unreliable service depending upon the size of the scheduled headway. Similar logic applies to simultaneity between transit service reliability and passenger demand. As delay variability increases, demand should decrease because of increased passenger wait times, yet a decrease in demand will reduce delay variability. A route-level model that addresses simultaneity between demand, supply, and service reliability would typically be set up like the following system of equations. Individual routes are denoted by the subscript (i).

$$\text{Boardings}_i = f(\text{headway}_i, \text{reliability}_i, x_{3i}, x_{4i}, \dots, x_{Ni})$$

$$\text{Headway}_i = f(\text{boardings}_i, \text{reliability}_i, x_{3i}, x_{4i}, \dots, x_{Ni})$$

$$\text{Reliability}_i = f(\text{boardings}_i, \text{headway}_i, x_{3i}, x_{4i}, \dots, x_{Ni})$$

In the example shown above, all 3 variables are treated as endogenous. At the route-level, the assumption of simultaneity between supply and demand and supply and reliability is valid. A problem arises when selecting an appropriate reliability measure to use in the equations. Mean departure delay does not adequately explain passenger demand or service supply at the route-level. For example, two minutes of mean departure delay at the route terminus does not sufficiently explain the number of mean boardings attributed to the route or the size of the scheduled headway. Mean headway delay is not a useful measure of transit service reliability at any level of analysis because the amount of headway delay cancels to zero if enough trips are sampled. Because passengers are more concerned about variability in bus performance, rather than mean performance, the reliability variable should capture the amount of deviation from the mean. Headway delay variation and departure delay variation are much better measures of transit service reliability. The use of either of these two variables in simultaneous equations estimation poses a dilemma that is hereafter referred to as *endogenous variables problem*. Although headway delay variation and departure delay variation are useful in explaining the number of mean boardings, mean boardings does not adequately explain variability in performance. The passenger activity variable that sufficiently explains variability in performance is boarding variation. This inconsistency precludes the direct measurement of simultaneity between transit service reliability and demand. The primary implication is that these variables must be treated as exogenous.

A number of other problems exist with route-level demand modeling. Boardings are assumed to be homogeneous along the entire route segment. This assumption is erroneous because demand is realized at the individual stop level. This makes it difficult to precisely control for the effects of

socioeconomic and demographic characteristics on ridership. Another problem concerns the location where reliability is measured. The most obvious place to measure reliability is at the route terminus, yet this is the location where delay variability tends to be worst and where few passengers are affected. Service supply is not properly addressed in simultaneous equations modeling. This is because passenger demand and supply only interact during peak periods of operation. During off-peak time periods, service frequency is usually set according to policy and is only partially related to the amount of passenger activity.

Another problem that exists in simultaneous equations estimation occurs because of inherent differences in the spatial relationships between variables. This is true at both the route and time point-levels of analysis and is hereafter referred to as the *spatial disparity problem*. This problem stems from the fact that both demand and reliability are stop-level phenomena, whereas transit service supply is set at the route or route-segment level. As an example, mean boardings are related to the size of the scheduled headway, yet the reverse relationship does not hold true. This is because **headways** are set according to passenger loads at the critical load point (a specific point location), not mean boardings associated with a time point or route. A similar problem concerns the nature of the relationship between transit service reliability and scheduled service. Although mean scheduled headway helps to explain variability in bus performance, variability in bus performance does not adequately explain mean scheduled headway because of the spatial inconsistency mentioned above. Delay variability at each time point does not adequately explain mean scheduled **headways** because **headways** are either set by policy or by demand at the maximum load point. For example, headway delay variation at time point 2 does not explain mean scheduled headway at time point 5, which contains the stop where maximum load is greatest. The spatial disparity problem precludes the use of a reliability variable in the supply equation.

The following series of equations are proposed for time point-level models. Individual time points are denoted by subscript (j) and the critical time point is denoted by subscript (z).

$$\text{Mean boardings}_j = f(\text{mean scheduled headway}_j, \text{delay variance}_j, x_{3j}, x_{4j}, \dots, x_{Nj})$$

Mean scheduled headway<sub>j</sub> = f(maximum load, x<sub>2j</sub>, x<sub>3j</sub>, x<sub>4j</sub>, ...x<sub>Nj</sub>)

Delay variance<sub>j</sub> = f(boarding variation<sub>j</sub>, mean scheduled headway<sub>j</sub>, x<sub>3j</sub>, x<sub>4j</sub>, ...x<sub>Nj</sub>)

The preceding discussion shows that there are stark differences between route-level and time point-level modeling of passenger demand, service supply, and transit service reliability.

Because of the endogenous variables problem and the spatial disparity problem, the estimation of separate models by ordinary least squares regression is more reasonable than *simultaneous* equations estimation.

## 5. Database Integration

Database integration is critical for advanced analysis of transit operations. In order to ensure data consistency, the various data sources must be related to a common geography (Peng & Dueker, 1994; Peng & Dueker, 1995). In this study, the common geographic unit is the time point.

Figure 5.1 shows the database integration scheme.

**Figure 5.1: Database Integration**

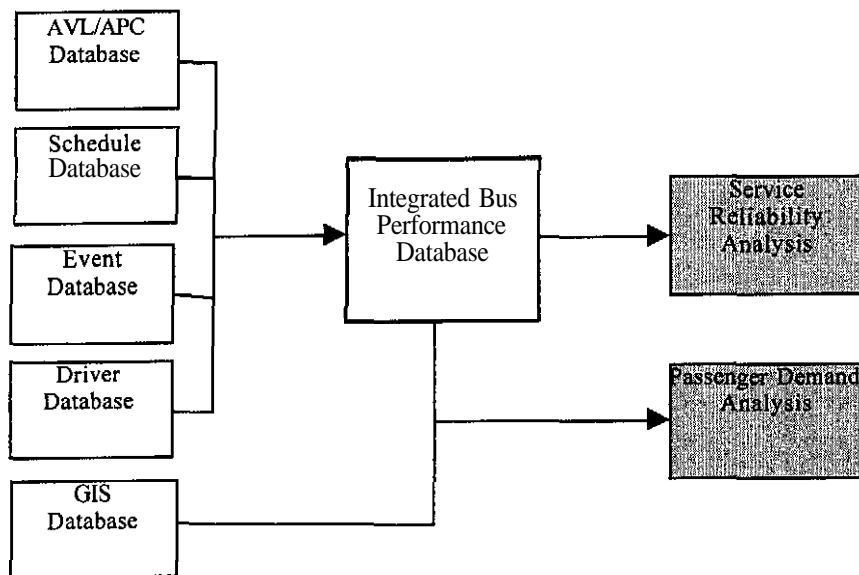

The integrated bus performance database requires information from five separate data sources. The AVL/APC database contains spatial and temporal information on archived bus operations and passenger activity. Event data are joined with operations data based upon time of occurrence

and assigned to the nearest stop. Driver information is integrated into the database according to badge number. The integrated bus performance database contains all of the necessary variables needed for analysis of transit service reliability. Passenger demand modeling requires additional information related to transit service areas that are obtained from a geographic information system (GIS) database.

A GIS was used to create time point service areas using a search routine based upon a quarter mile distance along the street network from each bus stop. Block-level socioeconomic data from the 1997 American Community Survey were assigned to transit service areas using an improved allocation technique that addressed double counting (overlapping service areas) with an algorithm that accounted for accessibility to stops associated with other routes. GIS data were obtained from Tri-Met, the City of Portland, and Metro's Regional Land Information System. The primary GIS coverages used in the analysis represent the street network, bus stop, bus route, park and ride, tax lot, employment location, and census block group.

In order to ensure spatial consistency, all data were assigned to time points. The data represent three different types of spatial measurement- point, polygon, and cumulative since previous time point. Figure 5.2. shows these different types of measurement in more detail. "TP" refers to time point and "TPSA" refers to time point service area.

**Figure 5.2: Data Consistency**

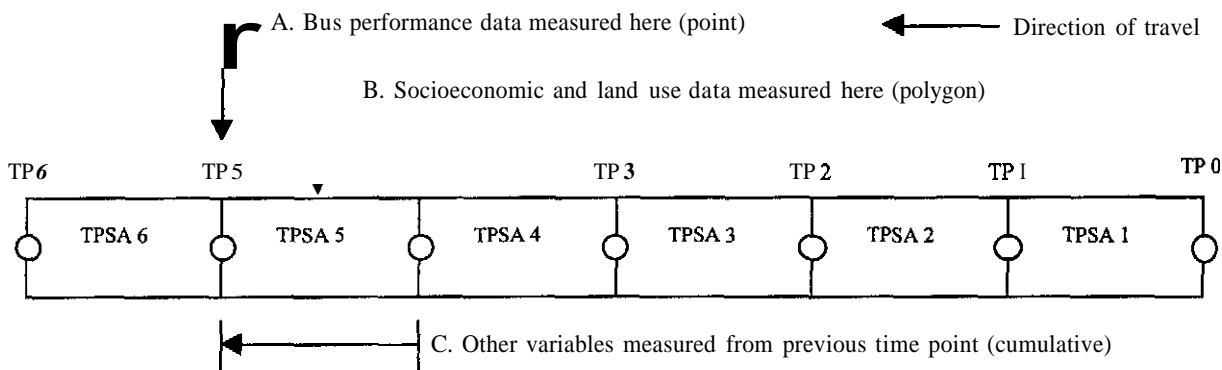

Bus performance is measured at the individual time point [A]. For example, mean departure delay at a particular time point may represent 2.5 minutes. Other variables such as mean

passenger boardings and the number of scheduled stops are cumulative variables measured from the previous time point [B]. Socioeconomic data are assigned to polygons representing time point service areas [C]. This common spatial structure is employed throughout the analysis.

In theory, delay variability at a particular time point is a function of everything that happens to a bus since it left the route origin. In both the demand and the reliability models, a measure of delay variation at the previous time point is used to control for the effects of cumulative distance. Figure 5.3 shows this notion in more detail. In the example shown below, delay variability is measured at time point 3 [A]. Controlling for delay variability at the previous time point [B] negates the need for cumulative variables measured from the route origin. All other variables are associated with the time point of interest [C].

**Figure 5.3: Model Structure**

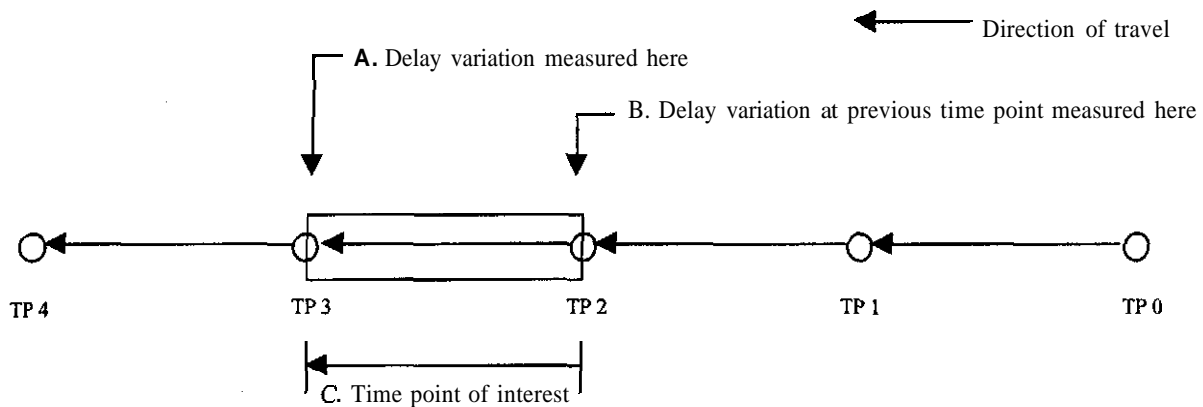

## 6. Study Design

A total of 5 radial routes (routes 4, 8, 14, 15 and 104) and 2 cross-town routes (routes 72 and 75) were used in the analysis. The selection of routes was based upon two principal factors, 1) a continuation of study routes analyzed in previous phases of the project, and 2) the need for representative cross-town route typology. The sampling period covers 19 weekdays of bus operations from October 4th-29th, 1999. The data are cross-sectional, meaning that the study is limited to explaining the determinants of passenger demand, service quantity, and service quality

for a given period of time. Tri-Met defines the following daily time periods: a.m. peak (7:00 a.m.-8:59 a.m.), midday (9:00 a.m.-3:59 p.m.), p.m. peak (4:00 p.m. -5:59 p.m.), evening (6:00 p.m.-1:59 a.m.), and night (2:00 a.m.-6:59 a.m.).

One of the main benefits of automated data collection systems such as the Tri-Met BDS is that sufficient data are generated to allow for measures of variability over time and space. Table 6.1 shows the structure of the bus performance database in detail for two of the study routes. The full table is included in the back of the report as Appendix 1.

**Table 6.1: Bus Performance Database Structure**

Route	Name	Typology	Dir.	Time	TPs	Trips	Days	Max. Obs.	Tot. Obs.	% Recov.	
14	Hawthorne	Radial	Out	1	6	16	19	1824	1530	83.88	
				2	6	31	19	3834	2867	74.78	
				3	6	27	19	3040	1376	45.26	
				4	6	14	19	1596	1068	66.92	
			In	1	6	27	19	2888	1952	67.59	
				2	6	30	19	3420	2856	83.51	
				3	6	16	19	1824	1128	61.84	
				4	6	12	19	1368	1068	78.07	
72	Killingsworth-S.E. 82nd	C-town	Out	1	9	17	19	2907	1593	54.80	
				2	9	38	19	6498	4041	62.19	
				3	9	23	19	3933	1872	47.60	
				4	9	14	19	2394	1251	52.26	
			In	1	9	18	19	3078	1720	55.88	
				2	9	39	19	6555	3918	59.77	
				3	9	23	19	3933	1989	50.57	
				4	9	14	19	2394	1359	56.77	
<b>Summary</b>								<b>TPs</b>	<b>Max. Obs.</b>	<b>Tot. Obs.</b>	<b>% Recov.</b>
Radial Total								260	83957	52879	62.98
Cross-town Total								152	56963	35121	61.66
Grand Total								412	140920	88000	62.45

Bus performance data were aggregated to capture variability in transit service reliability at each time point. An individual observation has a route, direction, time point, and time of day component (e.g., route 14, inbound, time point 5, time period 1). Maximum observations represents the number of observations that would have existed in the database if all records were clean. This is simply the number of time points times the number of trips times 19 days for each observation. These values were decremented for any service pattern changes. Total observations represents the number of clean records remaining in the database. Percent recovery shows the

percentage of valid observations to maximum observations. Overall, 88,000 records (62.45%) were successfully recovered from the archived bus operations data. The other records fell out because, 1) post-processing of the data resulted in the elimination of complete trips if they could not be successfully matched with the schedule, 2) passenger counts were missing because certain buses were not APC equipped (typically trippers brought on-line to serve peak periods only), and 3) headways could not be calculated because of missing reference buses.

Means and variances were calculated by summarizing data over all trips within a time period over all days. For example, departure delay variability for route 14, inbound, time point 5, time period 1 was calculated using the 27 trip records in the time period over 19 days. Route 14 contributes 48 time point observations ( $6 \text{ time points} * 4 \text{ time periods} * 2 \text{ directions} = 48$  observations) to the final data set. The final data set contains 260 radial and 152 cross-town observations for a grand total of 412 observations. Due to a limited number of degrees of freedom, both inbound and outbound directions of travel were included in the same models.

Table 6.2 shows the basic structure of the data set.

**Table 6.2: Model Structure**

Type [Routes]	Time of Day	Direction	N	Demand D.V.	Reliability D.V.
Radial [4, 8, 14, 15, 104]	A.M. Peak	In/Out	65	Boardings	Headway Delay
Radial [4, 8, 14, 15, 104]	Midday	KO!!!	65	Boardings	Departure Delay
Radial [4, 8, 14, 15, 104]	P.M. Peak	In/Out	65	Boardings	Headway Delay
Radial [4, 8, 14, 15, 104]	Evening	In/Out	65	Boardings	Departure Delay
Cross-town [72, 75]	A.M. Peak	In/Out	38	Boardings	Headway Delay
Cross-town [72, 75]	Midday	In/Out	38	Boardings	Departure Delay
Cross-town [72, 75]	P.M. Peak	In/Out	38	Boardings	Headway Delay
Cross-town [72, 75]	Evening	In/Out	38	Boardings	Departure Delay

## **7. Operational Models**

The following section concerns the operationalization of the passenger demand, service supply, and reliability models. The literature review, the discussion of problems related to time **point-** level modeling, and the nature of the data provided the basis for the structure of equations which follow. Table 7.1 represents a summary of the operational models.

**Table 7.1: Operational Models**

DEMAND	Radial				Cross-town			
	A.M.	Mid.	P.M.	Eve.	A.M.	Mid.	P.M.	Eve.
Variables								
Mean Boardings	•	•	•	•	•	•	•	•
Mean Sched. Headway	•	•	•	•	•	•	•	•
Departure Delay Variability @ PTP		•		•		•		•
Headway Delay Variability @ PTP	•		•		•		•	
Mean Sched. Stops	•	•	•	•	•	•	•	•
Population	•	•		•	•	•		•
Employment		•	•	•		•	•	•
Median HH Income	•	•		•	•	•		•
Transit Center [Dummy]	•	•	•	•				
Complimentary Routes					•	•	•	•
Downtown [Dummy]			•					
High School Enrollment		•				•		
Inbound [Dummy]	•	•		•				
Outbound [Dummy]			•					
Route 72 [Dummy]					•	•	•	•

SUPPLY	Radial				Cross-town			
	A.M.	Mid.	P.M.	Eve.	A.M.	Mid.	P.M.	Eve.
Variables								
Mean Scheduled Headway	•	•	•	•	•	•	•	•
Mean Load @ CTP	•	•	•	•	•	•	•	•
Pattern [Dummy]	•	•	•	•				

RELIABILITY	Radial				Cross-town			
	A.M.	Mid.	P.M.	Eve.	A.M.	Mid.	P.M.	Eve.
Variables								
Headway Delay Variability	•		•		•		•	
Departure Delay Variability		•		•		•		•
Mean Scheduled Headway	•	•	•	•	•	•	•	•
Boarding Variability	•	•	•	•	•	•	•	•
Departure Delay Variability @ PTP		•		•		•		•
Headway Delay Variability @ PTP	•		•		•		•	
Mean Scheduled Stops	•	•	•	•	•	•	•	•
Unscheduled Stop Variability	•	•	•	•	•	•	•	•
Lift Variability	•	•	•	•	•	•	•	•
Miles Per Hour Variability	•	•	•	•	•	•	•	•
Part-Time Driver Variability	•	•	•	•	•	•	•	•
Cumulative Events Variability	•	•	•	•	•	•	•	•
Variables	A.M.	Mid.	P.M.	Eve.	A.M.	Mid.	P.M.	Eve.
Inbound [Dummy]	•	•		•				
Outbound [Dummy]			•					
Route 72 [Dummy]					•	•	•	•

The dependent variable in the demand equations is mean boardings since previous time point. This is a cumulative measure that assigns boardings **from** each stop in the time point service area to the individual time point. The variable is averaged over all trips in the time period. The transit service reliability variable is headway delay variation in the morning and **afternoon** models and departure delay variation in the midday and evening models. This is consistent with existing theory regarding the relationship between service frequency and passenger wait times. A measure of delay variation since the previous time point is used to control for the existing level of **unreliability** and to test the supposition that delay variation influences passenger demand. Both delay variation and delay variation at the previous time point variables are expected to have negative impacts on demand. The mean number of scheduled stops is necessary in the demand equation because of its relation to the number of boardings.

In order to control for market size, boardings are modeled as a function of population in the a.m. peak time period and employment in the p.m. peak time period. Both population and employment are used in the midday and evening time periods because there is less of a directional bias in demand. Median household income is used in all time periods, except for the p.m. peak time period. Median household income is omitted from the p.m. peak models because it is assumed to be independent of demand as persons travel home from work. Another income effect variable, the number of zero auto households, was considered in the models but proved highly **collinear** with population. Median household income is expected to have a negative influence on boardings.

To control for additional sources of demand, a transit center dummy variable is used in the radial models only. This variable is intended to proxy for the effect of transferring passengers, drop offs, and park and **ride** passengers. The number of intersecting routes (complimentary routes) in the time point buffer is used in the cross-town models because there are few transit centers or park and ride lots associated with the cross-town study routes. This variable controls for ridership that may originate at non-timed transfer locations where cross-town routes intersect

radial routes. The reason that the number of complimentary routes is not used in the **radial** models is that downtown time points are associated with an excessive number of intersecting routes. A dummy variable for high school is included in the midday models to control for this additional source of demand. All of the variables that represent additional sources of ridership are expected to have a positive relationship to the number of mean boardings.

A downtown time point dummy variable is used in afternoon peak radial model only. The variable is used to control for any unknown phenomena occurring downtown that may affect boardings. The sign of the downtown dummy coefficient is expected to be positive. A dummy variable for direction is included in the radial models to control for any effects on demand due to direction. A dummy variable for route **72** is included in the cross-town models to test if there are any significant differences between cross-town study routes.

The dependent variable for the supply equations is mean scheduled headway. Previous studies have used service supply measures that take into account the amount of seating capacity. Because there exists little variation in seating capacity between the study routes, a composite service supply measure was not considered relevant. Mean maximum load at the critical time point is used as an explanatory variable in order to control for the effect of passenger loading on scheduled headways. This variable represents the average maximum load for all stops within a time point. The variable was further summarized by averaging over all trips within a time period. The value for mean maximum load at the critical time point was then assigned to every other time point on the route, thus becoming a route-level variable. This variable is expected to have a negative effect on mean scheduled headway.

A **dummy** variable representing service pattern is included in the radial models only because there are no major service pattern changes associated with the cross-town routes. The variable is intended to control for differences in **headways** attributable to a shortline service pattern. This variable is expected to have a positive effect on mean scheduled headway. Because of the spatial

disparity problem mentioned previously, a bus performance variable is not practicable in the supply equations. Other candidate variables for the supply models included direction and route specific dummy variables. Direction is applicable in the peak period models and would largely pick up the effect of deadheading. This variable was not tested because there are few deadheads associated with the study routes. Route specific dummy variables were be useful in the radial models, but could not be used because of a limited number of degrees of freedom.

The dependent variable in the reliability equations is mean headway delay variability in the peak period models and mean departure delay variability in the off-peak period models. This is in accordance with existing theory regarding service frequency and passenger wait times. Mean scheduled headway is included as an explanatory variable because of its relationship to **service** reliability. As mentioned previously, mean scheduled headway sets an upper limit on the amount of delay variation. The relationship between mean scheduled headway and delay variability is expected to be positive, with larger coefficients in the off-peak models. Similar to the demand equations, a reliability measure at previous time point is used to control for existing levels of **unreliability**. This relationship is also expected to be positive. Route characteristics are addressed through the use of a variable representing the mean number of scheduled stops. In theory, the greater the number of scheduled stops the greater the likelihood of delay variation.

Passenger activity is addressed in the reliability equations through the use of boarding variation and lift operation variation variables. It is hypothesized that these variables will have an adverse effect on the amount of delay variability. Part-time driver variability is used to control for the effects of driver experience. It is expected that greater part-time driver variability is related to greater levels of delay variability. Another driver-related variable concerns unscheduled stop variation. Because unscheduled stops represent a way for drivers to kill time if buses are running ahead of schedule, this variable will likely have a positive effect on delay variability.

A modified speed variable was created to serve as a proxy variable for excess traffic congestion. The variable was calculated by dividing scheduled distance by actual running time minus dwell time plus a penalty of 9 seconds for each actual stop to control for acceleration/deceleration delay and time spent merging back into traffic. This variable is expected to have a negative effect on bus performance. A measure of cumulative event variation was created to control for incidents likely to contribute to delay variation. Events were limited to those related to passenger, driver, mechanical, traffic, and emergencies. It is posited that event variability will adversely effect bus performance. Similar to the passenger demand models, a dummy variable for direction is included in the radial models to control for any differences in delay variation attributable to direction. The outbound direction is the reference case in all models except the afternoon peak where the inbound direction is used. A dummy variable for route 72 is included in the cross-town reliability models to ascertain whether this route behaves differently from route 75.

## **8. Results**

The following section describes the results of the regression output. Table 8.1 shows a detailed description of the variable names used in the regression models. The bus performance variables represent averages over all trips within a time period over 19 weekdays.

**Table 8.1. Description of Variables**

ONM	Cumulative boardings since previous time point (actual)
HWSM	Scheduled headway (seconds)
STOPSM	Scheduled stops since previous time point (actual)
DDVPTP	Departure delay variation at previous time point (seconds)
HDVPTP	Headway delay variation at previous time point (seconds)
ONV	Boarding variation (seconds)
POP	Population (actual)
EMP	Employment (actual)
TC	Transit center (dummy)
COMPL	Complimentary routes (actual)
INCHH	Median household income (\$ actual)
DTOWN	Downtown (dummy)
SCHL	High school (dummy)
R72	Route 72 (dummy)
IN	Inbound direction (dummy)
OUT	Outbound direction (dummy)
LOADCTP	Mean maximum load at critical time point (actual)
PAT	Shortline pattern (dummy)
HDV	Departure delay variation (seconds)
DDV	Headway delay variation (seconds)
ONV	Cumulative boarding variation
USTOPV	Unscheduled stop variation
LIFTV	Lift operation variation
EVENIV	Delay event variation
PTDV	Part-time driver variation
MPHV	Link speed variation

Table 8.2 shows the results of the passenger demand models. The dependent variable in the demand models is mean boardings. The results show that mean scheduled headway does not have a significant effect on mean boardings in any of the models. This is because the relationship between supply and demand is not as pronounced in time point-level modeling. At the route-level, service frequency is almost always a significant determinant of ridership. This does not hold at the time point-level because of the spatial disparity problem. For any given route during peak periods, there will be time points with relatively good service, yet few boarding passengers. This is because headways are set according to passengers loads that may or may not be associated with a given time point. Because headways are set according to policy during off-peak periods, this variable was not expected to be significant in the non-peak period models.

In all models, headway delay variability since the previous time point or departure delay variability since the previous time point are statistically significant and have a negative effect on mean passenger demand. This indicates that unreliable service has an adverse effect on mean boardings in time point-level demand modeling. The largest impact of headway delay variation at the previous time point on passengers demand is associated with the radial p.m. peak model, followed by the cross-town a.m. peak model. The coefficients for departure delay variation at the previous time point are highest for the radial and cross-town evening models.

In all models, headway delay variability since the previous time point or departure delay variability since the previous time point are statistically significant and have a negative effect on mean passenger demand. This indicates that poor transit service reliability has an adverse effect on mean boardings in time point-level demand modeling. The largest impact of headway delay variation at the previous time point on passengers demand is associated with the radial p.m. peak model, followed by the cross-town a.m. peak model. The **coefficients** for departure delay variation at the previous time point are highest for the radial and cross-town evening models. It is possible to perform sensitivity analysis on the relationship between delay variability and mean **boardings**. As an example, a 10% reduction in headway delay variation at the previous time point on radial routes in the a.m. peak leads to a increase in 0.17 passengers per trip per time point. This was calculated by taking 10% of the mean headway delay variation at the previous time point and multiplying it by the size of the coefficient [ $4953.6 * -0.00003349 = 0.17$  boardings].

The number of mean scheduled stops is an important determinant of passenger demand in the radial morning, midday, and evening models.

**Table 8.2. Regression Results: Demand Models**

DEMAND	Radial				Cross-town			
	Morning Peak	Midday	Afternoon Peak	Evening	Morning Peak	Midday	Afternoon Peak	Evening
ONM	DV	DV	DV	DV	DV	DV	DV	DV
HWSM	-0.4924E-03 (0.2268)	-0.1725E-02 (-1.194)	0.3508E-02 (1.561)	-0.2091E-02 (-1.384)	0.9607-02 (0.6086)	-0.6474E-02 (-0.1316)	-0.1453E-01 (-1.448)	-0.2707E-01 (-1.070)
STOPSM	0.3228 (2.260) **	0.2974 (1.985) **	0.2256 (1.554)	0.3964 (2.393) **	0.3669 (1.432)	0.3027 (0.8736)	0.2530 (1.439)	0.2289 (1.261)
DDVPTP		-0.1103E-03 (-3.853) **		-0.1567E-03 (-4.650) **		-0.1258E-03 (-2.025) **		-0.1357E-03 (-3.702) **
HIDVPTP	-0.3349E-04 (-2.965) **		-0.1255E-03 (-5.548) **		-0.1111E-03 (-3.848) **		-0.6940E-04 (-3.816) **	
POP	0.2402E-02 (4.570) **	0.1181E-02 (1.942) *		-0.6280E-03 (-1.006)	0.2439E-03 (0.1865)	-0.8620E-03 (-0.5224)		-0.5567E-03 (-0.6643)
EMP		0.1368 E-02 (3.214) **	0.2180E-02 (3.588) **	0.1190E-02 (2.737) **		-0.9108E-03 (-0.5309)	-0.1302E-02 (-0.8858)	-0.8989E-04 (-0.9344E-01)
TC	2.3339 (1.738) *	0.6679 (0.4689)	-0.8925 (-0.4455)	-0.5363 (-0.3519)				
COMPL					-0.4272 (-1.178)	-0.9394E-01 (-0.2115)	-0.2968 (-0.7538E-01)	-0.8754E-01 (-0.3392)
HHINC	-0.1909E-03 (-3.403) **	-0.1312E-03 (-2.097) **		-0.1427E-03 (-2.142) **	-0.1867E-06 (-0.3937E-02)	0.1969E-03 (1.135)	0.1768E-03 (1.162)	0.9296E-04 (0.8567)
DTOWN			3.5638 (1.754) *					
SCHL		-0.8229 (-0.7128)				2.0215 (0.9491)		
IN	3.8139 (4.263) **	-2.3355 (-1.886) *		-5.0788 (-4.020) **				
OUT			7.7938 (4.417) **					
R72					4.3072 (1.510)	-1.7274 (-0.1386)	-3.7441 (-1.343)	-1.3185 (-0.3873)
CONST	3.1 (1.444)	9.0999 (3.749) **	3.1908 (1.190)	12.813 (4.568) **	-0.3557 (-0.2833E-01)	8.8331 (0.2201)	16.220 (1.794) *	28.150 (1.203)
R2	0.6069	0.4762	0.5226	0.4256	0.3526	0.0772	0.2762	0.2839

In theory, the more stops serving a time point, the greater the ridership potential. The size of the coefficients indicates that an increase in 1 scheduled stop, results in an increase of 0.32, 0.30, and 0.40 passengers per trip for the morning, midday, and evening time periods respectively.

Although the mean number of scheduled stops is not statistically significant in the afternoon peak time period, it still represents the best point estimate of the effect of scheduled stops on passenger demand. The variable did not prove statistically significant in any of the cross-town models.

Population is an important explanatory variable in the radial models in the a.m. peak and midday time periods. The signs of the coefficients are positive, with the size of the coefficient being greater for the a.m. peak model. The interpretation of the coefficient for population in the a.m. peak model is that a 100 person increase time point population leads to an increase of 0.24 riders per time point. The best way to interpret this variable is to multiply the value of the coefficient by the expected population increase (or decrease) by the number of trips serving the time period. Using the above example, an increase in demand of 0.24 riders per trip times 13 trips serving the time period equals a ridership increase of 3.24 patrons per time point for the time period.

Employment proves to be an important variable in the radial midday, afternoon peak, and evening models. An increase in employment of 100 persons per time point would result in a 0.14, 0.22, and 0.12 increase in mean boardings per trip per time point for the midday, afternoon peak, and evening time periods respectively. Note that employment proxies for non-residential activity locations in the evening models. Neither population nor employment are important determinants of passenger demand in the cross-town models. This finding seems reasonable considering the nature of cross-town routes and the characteristics of the market areas served.

Median household income is an important explanatory variable in the radial models, but not the cross-town models. As expected, income is negatively associated with transit demand. The effect of income on boardings is greatest during the morning peak time period. The morning peak

income coefficient yields an estimate of a 0.19 decrease in mean boardings for every \$1000 increase in median household income in the time point buffer.

A number of variables were used to control for the effects of other sources of originating riders on passenger demand. A transit center dummy was used in the radial models to proxy for additional sources of originating riders in the form of transfers and persons using park and ride facilities. The variable is significant in the a.m. peak model. The presence of a transit center associated with a time point contributes an average of 2.33 riders per trip. The variable associated with additional sources of passengers in the cross-town models, the number of intersecting routes, had no effect on mean boardings. A **downtown** dummy variable was included in the radial afternoon peak model to control for unknown effects on demand associated with time points contained wholly within or intersecting downtown. The variable proved moderately significant, contributing an average of 3.56 passengers per trip. The high school dummy variable used in the radial and cross-town midday models had no effect on mean boardings.

Direction is an important variable in **all** of the radial models. The reference case is the outbound direction for the morning, midday, and evening models. The size of the coefficients indicates that the inbound direction accounts for 3.81 passengers in the morning time period, -2.34 passengers in the midday time period, and -5.08 passengers in the evening time period. The negative value for the midday time period is counterintuitive. For the afternoon peak model, the reference case is the inbound direction. On average, the outbound direction in the afternoon time period accounts for 8.00 additional passengers. A directional dummy variable was not tested in the cross-town models.

The radial models explain 43-61% of the variation in mean boardings. The highest  $R^2$  values are for the morning and afternoon peak period models, at 61% and 52% respectively. Only 8-34% of the variation in mean boardings is explained on cross-town routes with these model specifications. The low amount of explained variance in the cross-town models is largely the

result of modeling a fairly ubiquitous level of demand at the time point-level of analysis. It is apparent that time point-level modeling is much more suited to analyzing factors affecting passenger demand on radial routes. The results of the model are generally consistent with other passenger demand studies in that income and market size (**population/employment**) are shown to be significant determinants of demand. Other important findings are that frequency of service has no effect on demand in time point-level modeling and that unreliable service is shown to adversely influence passenger demand.

The dependent variable in the supply equations is mean scheduled headway. Table 8.3 shows the results of the supply models.

**Table 8.3. Regression Results: Supply Models**

SUPPLY	Radial				Cross-town			
	Morning Peak	Midday	Afternoon Peak	Evening	Morning Peak	Midday	Afternoon Peak	Evening
HWSM	DV	DV	DV	DV	DV	DV	DV	DV
LOADCTP	-11.386 (-6.384) **	-11.9450 (-2.783) **	-10.767 (-4.973) **	-5.8828 (-3.690) **	-20.022 (-6.374) **	-39.361 (-15.08) **	-49.119 (-7.213) **	-13.808 (-23.71) **
PAT	644.403 (10.970) **	979.73 (29.830) **	890.79 (15.190) **	1001.9 (32.54) **				
CONST	940.47 (21.530) **	1096.3 (10.800) **	932.77 (15.140) **	972.95 (31.21) **	1124.9 (17.09)	1592.6 (27.44) **	1750.2 (10.88) **	1052.5 (105.2) **
R2	0.7277	0.9424	0.7966	0.9446	0.5172	0.8596	0.5797	0.9382

The variable for mean maximum load at the critical time point is significant in all time periods for both radial and cross-town models. Interestingly, maximum load at the critical time point is shown to be an important explanatory variable in the off-peak models. This is surprising because it was not expected that there would be a strong relationship between passenger loads and policy headways. A dummy variable for route pattern was included in the radial models to control for the effects of shortlined trips on scheduled headways. The variable proved statistically significant in all time periods. For the radial models, 72-94% of the variation in scheduled

headway is explained with just two variables. For the cross-town models, the models explain 52-93% of the amount of variation in mean scheduled headway. The amount of variation explained in peak period models is lower than that for off-peak period models.

The dependent variable in the reliability equations is mean departure delay variation for the off-peak models and mean headway delay variation for the peak models. Table 8.4 shows the results of the transit service reliability models.

**Table 8.4. Regression Results: Reliability Models**

RELIABILITY	Radial				Cross-town			
	Morning Peak	Midday	Afternoon Peak	Evening	Morning Peak	Midday	Afternoon Peak	Evening
HDV	DV		DV		DV		DV	
DDV		DV		DV		DV		DV
HWSM	67.74 (3.750) **	-4.9284 (-0.4973)	1.4910 (0.1440)	2.7441 (0.5408)	148.23 (4.255) **	-0.8578 (-0.8495E-02)	221.90 (9.039) **	86.242 (0.4782)
ONCV	368.15 (1.422)	-55.698 (-0.3423)	55.601 (0.4285)	34.863 (0.3547)	71.219 (1.243)	-60.691 (-1.034)	-38.808 (-0.5916)	-462.43 (-1.718) *
HDVPTP	0.6811E-01 (0.6215)		1.1385 (10.14) **		1.1036 (19.15) **		1.1124 (25.26) **	
DDVPTP		1.1089 (7.675)		1.2773 (9.841) **		1.3113 (10.81) **		1.3319 (4.817)
STOPSM	2249.2 (1.848) *	1815.5 (2.424) **	2753.9 (3.722) **	264.51 (0.5907)	1179.1 (4.182) **	893.82 (2.092) **	560.86 (1.562)	910.44 (1.410)
USTOPV	-10717.0 (-0.9987)	10217.0 (1.376)	34.067 (0.4335E-02)	-2808.7 (-0.5394)	-5547.8 (-1.140)	993.37 (0.1249)	-4172.8 (-0.5736)	-9930.6 (-0.7142)
LIFTV	0.4445E+06 (2.667) **	2977.1 (0.5187E-01)	-49673.0 (-1.089)	77135.0 (2.144) **	77410.0 (2.315) **	0.1277E+06 (3.598)	69598.0 (1.541)	0.1359E+06 (1.676)
EVENTV	0.8750E+06 (1.632)	0.4830E+06 (1.522)	0.5757E+06 (3.428) **	-0.2717E+06 (-1.450)	15221.0 (0.1020)	-0.3085E+06 (-1.195)	0.2264E+06 (1.617)	0.4605E+06 (1.336)
PTDV	0.5417E+06 (3.583) **	-0.1895E+06 (-2.700) **	-0.1981E+06 (-0.8940)	-40673.0 (-0.9189)	-0.1436E+06 (-0.8558)	-36703.0 (-0.3281)	0.1369E+06 (1.985)	0.1067E+06 (1.312)
MPHV	1350.4000 (9.480) **	632.12 (5.676) **	708.19 (4.908) **	164.88 (2.195) **	304.23 (3.328) **	129.77 (1.714) *	-330.97 (-3.025) **	-9.4889 (-0.2799)
R72					38383.0 (2.060) **	9196.6 (0.3901)	37434.0 (6.375) **	-2340.3 (-0.1057)
IN	-30908.0 (-3.278) **	-7574.2 (-0.9018)		-1851.3 (-0.3847)				
OUT			1783.7 (0.2106)					
CONST	-0.1750E+06 (-4.758) **	1221.9 (0.7712E-01)	-3766.9 (-0.6324E-01)	-2041.4 (-0.1621)	-0.1166E+06 (-5.110) **	-14010.0 (-0.1494)	-0.1743E+06 (-7.343) **	-94819.0 (-0.5520)
R2	0.8105	0.7189	0.8772	0.8126	0.9670	0.8947	0.9755	0.7331

Mean scheduled headway proves to be an important **explanatory** variable in the radial a.m. peak model and both cross-town peak models. This shows that frequency of service is positively associated with delay variation and is consistent with the argument by previous researchers that the amount of scheduled service sets an upper bound on service **unreliability**. The relationship between mean scheduled headway and delay variation is positive. Contrary to expectations, service frequency did not prove significant in the radial afternoon peak model.

In all models except for the radial a.m. peak model, headway delay variability or departure delay since variability since the previous time point are significant determinants of unreliable service. The policy implication is that efforts to minimize delay at earlier points along a route will produce benefits at subsequent locations. For the peak period models, the largest coefficient for headway delay variation at the previous time point is associated with the radial p.m. peak model, followed by the cross-town p.m. peak model. For the off-peak models, the radial midday and evening models have smaller coefficients for departure delay variation at the previous time point compared to the cross-town models. Because the dependent and independent variables are both measured as delay variances, there is a direct interpretation of the sizes of the coefficients. For example, a 1.00 second increase in headway delay variation at the previous time point in the radial afternoon peak model leads to a 1.14 second increase in headway delay variation at subsequent time points.

Mean boarding variation has no statistically significant effect on delay variation in any of the models, except for a moderate effect with the wrong sign in the evening cross-town model. The finding that boarding variation does not appear to be an important contributor to delay runs contrary to conventional wisdom about the relationship between transit service reliability and passenger demand variation. It is widely believed that passenger demand variation is a cause of unreliable service, yet the opposite effect may be more important- that unreliable service causes passenger demand variation.

The mean number of scheduled stops is an important determinant of delay variation in the morning, midday, and afternoon models, and the cross-town morning and midday models. The relationship is positive, with an increase in the number of scheduled stops leading to an increase in delay variation. The size of the coefficients are largest for the radial **p.m.** peak model, followed by the radial a.m. peak model. Mean unscheduled stop variability has no effect on delay variation in any of the models. This finding is not surprising given that unscheduled stops represent a way for drivers to kill time when buses they are running ahead of schedule. Mean lift variability is shown to adversely impact service reliability in the radial morning and evening models. For cross-town models, the variable proves significant in the morning and midday models. The size of the coefficients is substantial largely because lifts operations are infrequent. Event variability is an important determinant of unreliable service in the radial afternoon peak period model. Because events are largely outside of the control of the transit agency, this finding has little policy significance.

Part-time driver variability has differing effects on delay variation depending upon the model. The coefficients are significant and positive in the radial **morning** and cross-town afternoon peak models, yet are significant and negative in the radial midday model. The reasons for the negative sign on the radial midday coefficient may be due to the fact that there is very little variation in the variable. In the cross-town models, the dummy variable for route 72 is statistically significant in the peak period models. This means that there are measurable differences between these two routes, with delay variability being higher for route 72 than route 75.

Variability in link speed is an important determinant of unreliable service in all models except for the cross-town evening model. This variable was designed to proxy for variation in auto travel speeds to reflect excess levels of traffic congestion. The relationship between link speed variability and unreliable service is positive except for a counterintuitive sign in the cross-town afternoon peak model.

The dummy variable for inbound direction is a significant explanatory variable in the radial **a.m.** peak model. Inbound bus trips are associated with a reduction in headway delay variability relative to outbound trips. This is because there is excess running time built into schedules in the **a.m.** peak period on radial routes. **An** interesting finding is that there is no statistically significant difference in headway delay variation attributable to direction in the afternoon peak time period. The reason for this may lie in the fact that both inbound and outbound trips in the afternoon peak face similar operating conditions as the transportation system is generally congested.

The transit service reliability models perform reasonably well, explaining anywhere from 71-98% of the variation in headway delay and departure delay variability. Slightly more variation is explained in the peak period models compared to the off-peak period models. In contrast to the cross-town demand models, the cross-town reliability models perform well at the time **point-**level of analysis. In general, the transit service reliability models show that service frequency, existing levels of delay variation, the number of scheduled stops, link speed variability, and direction in the radial **a.m.** peak model are significant determinants of delay variation. Boarding variation is found to have a negligible effect on service reliability.

## **9. Conclusions**

This report outlined a framework for analyzing passenger demand and transit service reliability at the time point-level of analysis. It has been shown that time-point level demand models are structurally different from route-level demand models. In particular, there exist unique spatial relationships between variables that prohibit the use of simultaneous equations modeling. The spatial disparity problem results from the fact that passenger demand and reliability are **stop-**level phenomena, whereas transit service supply is related to routes or route-segments. The endogenous variables problem stems from the fact that different measures (means and variances) of certain key variables are required depending upon the specific equation. The implications of

both of these sets of problems are that demand, supply, and reliability cannot be simultaneously determined in a time point-level model.

Automated data collection systems such as the Tri-Met BDS are providing new opportunities for advanced analysis of transit performance and passenger demand modeling. A key contribution of this research has been to link data typically associated with operations control and performance monitoring with service planning through use of a common geographic data structure (Strathman, Dueker, & Peng, 1997; Furth, 2000). This was accomplished through use of an integrated bus performance database and a GIS. The data structure employed in this research allowed for measures of variation over time and space. A considerable amount of information was summarized and integrated into a spatially consistent data set.

One of the main theoretical underpinnings of this research is that service quality, represented by variation in bus performance, affects the demand for transit. The models developed in this study utilize different bus performance measures depending upon frequency of service. This was done in an attempt to address unreliable service from the perspective of passengers. **An** important aspect of this research was to use measures of variability in bus performance to explain passenger boardings. The regression results indicate that variability in bus performance has an adverse effect on mean boardings for both radial and cross-town routes at the time point-level of analysis. Factors found to be important determinants of mean boardings on radial routes include the number of scheduled stops, population (a.m. peak), employment, income, and direction. Contrary to previous studies, service supply was not found to be significant. The cross-town demand models **performed** rather poorly except for the bus performance variables. An attempt was made to model the supply of transit at the time point-level as a function of peak passenger load and service pattern. Both variables proved significant in explaining mean scheduled headway. The reliability models **performed** well for both radial and cross-town routes. Factors found to be important determinants of delay variation include existing levels of **unreliability**, variability in link travel speed, and mean scheduled headway (**peak** period models except p.m.

peak). Variables found to vary in importance between models include the number of scheduled stops, lift operation variability, event variability (p.m. peak only), and part time driver variability. Direction was found to be an important determinant of delay variation in the a.m. peak radial model only. Surprisingly, boarding variation did not have any effect on service reliability.

The preceding analysis suggests a number of directions for future research. One of the more logical extensions pertains to functional form. The relationships between the dependent and independent variables may not be linear. Passenger demand studies have typically sought to explain mean **boardings**. This is largely because of difficulties associated with collecting data on ridership. New technologies such as APC technology collect sufficient amounts of data to allow for analysis of passenger loads. This would be particularly useful for peak period models where bus bunching represents an inefficient use of resources from the perspective of operators and where seating capacity constraints (pass-ups and overloads) represent poor quality service from the perspective of passengers. Lastly, it appears that time-point analysis of passenger demand on cross-town routes requires rethinking since very few of the standard explanatory variables proved significant.

# Appendix 1: Bus Performance Database Structure

Route	Name	Typology	Dir.	Time	TPs	Trips	Days	Max. Obs.	Tot. Obs.	% Recov.
4	Fesseden	Radial	Out	1	6	14	19	1596	900	56.39
				2	6	24	19	2736	1692	61.84
				3	6	16	19	1824	895	49.07
				4	6	13	19	1482	690	46.56
			In	1	6	13	19	1482	1020	68.83
				2	6	26	19	2964	1728	58.30
				3	6	18	19	1824	995	54.55
				4	6	11	19	1235	657	53.20
8	N.W. 15th	Radial	Out	1	7	11	19	1254	808	64.43
				2	7	24	19	2736	2090	76.39
				3	7	17	19	1919	1310	68.26
				4	7	12	19	1292	938	72.60
			In	1	8	14	19	1539	699	45.42
				2	8	24	19	2850	1804	63.30
				3	8	12	19	1482	775	52.16
				4	8	13	19	1482	752	50.74
14	Hawthorne	Radial	Out	1	6	14	19	1824	1590	83.88
				2	6	31	19	3834	2887	74.78
				3	6	27	19	3040	1376	45.26
				4	6	14	19	1596	1068	66.92
			In	1	6	27	19	2888	1932	67.59
				2	6	30	19	3420	2856	83.51
				3	6	16	19	1824	1128	61.84
				4	6	12	19	1368	1068	78.07
15	Belmont	Radial	Out	1	6	16	19	1824	1409	77.25
				2	6	30	19	3420	2483	72.60
				3	6	22	19	2489	1559	62.64
				4	6	13	19	1482	959	64.71
			In	1	6	27	19	2698	1989	73.72
				2	6	30	19	3420	2322	67.89
				3	6	16	19	1824	1038	56.91
				4	6	12	19	1368	924	67.54
104	Division	Radial	Out	1	7	11	19	1311	903	68.88
				2	7	25	19	2869	1599	55.73
				3	7	19	19	2185	982	44.94
				4	7	13	19	1501	776	51.70
			In	1	7	20	19	2318	1303	56.21
				2	7	27	19	3059	1652	54.00
				3	7	13	19	1463	796	54.41
				4	7	11	19	1235	589	47.69
72	Killingsworth-S.E. 82nd	C-town	Out	1	9	17	19	2907	1593	54.80
				2	9	38	19	6498	4041	62.19
				3	9	23	19	3933	1872	47.60
				4	9	14	19	2394	1251	52.26
			In	1	9	18	19	3078	1720	55.88
				2	9	39	19	6555	3918	59.77
				3	9	23	19	3933	1989	50.57
				4	9	14	19	2394	1359	56.77
75	S.E. 39th-Lombard	C-town	Out	1	10	15	19	2850	2099	73.65
				2	10	26	19	4940	3660	74.09
				3	10	15	19	2566	2017	78.60
				4	10	12	19	2166	1582	73.04
			In	1	10	15	19	2850	1260	44.21
				2	10	25	19	4750	3190	67.16
				3	10	15	19	2850	1850	64.91
				4	10	13	19	2299	1720	74.82
Radial Total					260			83957	52879	62.98
Cross-town Total					152			56963	35121	61.66
Grand Total					412			140920	88000	62.45

## Appendix 2: Descriptive Statistics

### Radial: A.M. Peak

Name	N	Mean	Std. Dev.	Var.	Min.	Max
ONM	65	5.922	5.103	26.039	0.031	22.685
HWSM	65	762.570	280.470	78661.000	429.610	1746.000
HDV	65	60440.000	69116.000	4777100000.000	10647.000	528470.000
HDVPTP	65	49536.000	48137.000	2317200000.000	8481.500	329010.000
POP	65	1647.300	1193.000	1423300.000	14.000	4031.000
TC	65	0.123	0.331	0.110	0.000	1.000
INCHH	65	25236.000	8510.400	72426000.000	6114.000	39852.000
IN	65	0.508	0.504	0.254	0.000	1.000
LOADCTP	65	21.719	10.288	105.840	8.132	34.381
PAT	65	0.108	0.312	0.098	0.000	1.000
ONV	65	15.963	19.093	364.530	0.051	102.970
STOPSM	65	10.815	4.108	16.872	2.000	20.000
USTOPV	65	0.579	0.509	0.259	0.010	2.431
LIFTV	65	0.020	0.029	0.001	0.000	0.149
EVENTV	65	0.006	0.008	0.000	0.000	0.034
PTDV	65	0.214	0.028	0.001	0.142	0.250
MPHV	65	31.392	31.708	1005.400	6.811	219.990

### Radial: Midday

Name	N	Mean	Std. Dev.	Var.	Min.	Max
ONM	65	6.227	4.675	21.856	0.059	22.565
HWSM	65	923.930	325.270	105800.000	710.540	1861.500
DDV	65	44990.000	37429.000	1400900000.000	7814.800	239110.000
DDVPTP	65	34348.000	22754.000	517750000.000	5503.500	88582.000
POP	65	1647.300	1193.000	1423300.000	14.000	4031.000
EMP	65	1413.100	1208.400	1460200.000	72.000	5740.000
TC	65	0.123	0.331	0.110	0.000	1.000
SCHL	65	0.215	0.414	0.172	0.000	1.000
INCHH	65	25236.000	8510.400	72426000.000	6114.000	39852.000
IN	65	0.508	0.504	0.254	0.000	1.000
LOADCTP	65	23.267	2.391	5.716	20.264	26.985
PAT	65	0.108	0.312	0.098	0.000	1.000
ONV	65	20.183	23.408	547.950	0.316	122.920
STOPSM	65	10.831	4.137	17.112	2.000	20.000
USTOPV	65	0.666	0.497	0.247	0.023	2.323
LIFTV	65	0.060	0.050	0.002	0.000	0.206
EVENTV	65	0.008	0.010	0.000	0.000	0.048
PTDV	65	0.197	0.045	0.002	0.104	0.251
MPHV	65	33.186	26.673	711.440	8.506	141.990

### Radial: P.M. Peak

Name	N	Mean	Std. Dev.	Var.	Min.	Max
ONM	65	7.200	7.172	51.438	0.293	40.651
HWSM	65	736.990	324.930	105580.000	398.440	1831.500
HDV	65	85617.000	56681.000	3212700000.000	16303.000	384290.000

[Radial: P.M. Peak Continued]

Name	N	Mean	Std. Dev.	Var.	Min.	Max
HDVPTP	65	69965.000	38782.000	1504100000.000	13368.000	162210.000
EMP	65	1413.100	1208.400	1460200.000	72.000	5740.000
TC	65	0.123	0.331	0.110	0.000	1.000
DTOWN	65	0.154	0.364	0.132	0.000	1.000
OUT	65	0.492	0.504	0.254	0.000	1.000
LOADCTP	65	27.093	8.463	71.617	17.167	37.696
PAT	65	0.108	0.312	0.098	0.000	1.000
ONV	65	25.026	31.464	989.950	0.259	156.910
STOPSM	65	10.708	4.042	16.335	2.000	20.000
USTOPV	65	0.644	0.476	0.226	0.036	1.989
LIFTV	65	0.057	0.061	0.004	0.000	0.263
EVENTV	65	0.015	0.019	0.000	0.000	0.080
PTDV	65	0.241	0.014	0.000	0.203	0.253
MPHV	65	26.457	20.686	427.920	6.883	129.660

### Radial: Evening

Name	N	Mean	Std. Dev.	Var.	Min.	Max
ONM	65	4.345	4.808	23.121	0.079	29.590
HWSM	65	972.790	326.170	106390.000	747.170	2057.100
DDV	65	42082.000	29062.000	844610000.000	6516.900	132060.000
DDVPTP	65	32735.000	19903.000	396130000.000	6312.200	78076.000
POP	65	1647.300	1193.000	1423300.000	14.000	4031.000
EMP	65	1413.100	1208.400	1460200.000	72.000	5740.000
TC	65	0.123	0.331	0.110	0.000	1.000
INCHH	65	25236.000	8510.400	72426000.000	6114.000	39852.000
IN	65	0.508	0.504	0.254	0.000	1.000
LOADCTP	65	18.367	6.032	36.390	9.891	29.128
PAT	65	0.108	0.312	0.098	0.000	1.000
ONV	65	13.131	22.256	495.340	0.139	144.190
STOPSM	65	10.831	4.137	17.112	2.000	20.000
USTOPV	65	0.521	0.436	0.190	0.030	2.063
LIFTV	65	0.042	0.050	0.002	0.000	0.274
EVENTV	65	0.007	0.010	0.000	0.000	0.039
PTDV	65	0.198	0.042	0.002	0.129	0.251
MPHV	65	32.698	25.768	663.990	5.854	151.600

### Cross-town: A.M. Peak

Name	N	Mean	Std. Dev.	Var.	Min.	Max
ONM	38	7.107	4.521	20.437	0.492	18.944
HWSM	38	709.670	83.183	6919.400	587.430	865.520
HDV	38	55151.000	33602.000	1429100000.000	16062.000	173450.000
HDVPTP	38	43877.000	24727.000	611420000.000	9016.100	105330.000
POP	38	1841.500	824.040	679040.000	399.000	3837.000
COMPL	38	4.447	2.251	5.065	2.000	12.000
INCHH	38	20022.000	5221.200	27261000.000	20452.000	41054.000
R72	38	0.474	0.506	0.256	0.000	1.000
LOADCTP	38	20.710	3.025	9.152	17.637	24.955
ONV	38	24.421	25.043	627.140	0.796	125.610

### [Cross-town: A.M. Peak Continued]

Name	N	Mean	Std. Dev.	Var.	Min.	Max
STOPSM	38	13.421	4.506	20.304	5.000	21.000

USTOPV	38	0.532	0.310	0.096	0.058	1.424
LFTV	38	0.023	0.035	0.001	0.000	0.150
EVENTV	38	0.007	0.008	0.000	0.000	0.031
PTDV	38	0.172	0.047	0.002	0.123	0.231
MPHV	38	27.081	16.021	256.680	10.494	80.615

### Cross-town: Midday

Name	N	Mean	Std. Dev.	Var.	Min.	Max
ONM	38	7.501	4.531	20.527	1.183	19.978
HWSM	38	725.610	132.670	17603.000	572.210	879.500
DDV	38	35397.000	23829.000	567810000.000	7330.600	108150.000
DDVPTP	38	26466.000	15606.000	243550000.000	2955.400	60343.000
POP	38	1841.500	824.040	679040.000	399.000	3837.000
EMP	38	1001.600	573.390	328780.000	69.000	2735.000
COMPL	38	4.447	2.251	5.065	2.000	12.000
INCHH	38	29922.000	5221.200	27261000.000	20452.000	41054.000
SCHL	38	0.237	0.431	0.186	0.000	1.000
R72	38	0.474	0.506	0.256	0.000	1.000
LOADCTP	38	22.027	3.132	9.809	18.884	26.486
ONV	38	29.615	26.738	714.940	2.292	107.730
STOPSM	38	13.421	4.506	20.304	5.000	21.000
USTOPV	38	0.600	0.284	0.080	0.094	1.129
LFTV	38	0.048	0.043	0.002	0.002	0.172
EVENTV	38	0.008	0.006	0.000	0.000	0.029
PTDV	38	0.203	0.032	0.001	0.139	0.242
MPHV	38	30.554	23.215	538.950	12.427	116.370

### Cross-town: P.M. Peak

Name	N	Mean	Std. Dev.	Var.	Min.	Max
ONM	38	7.904	4.881	23.825	1.035	21.124
HWSM	38	593.640	116.670	13613.000	460.670	887.580
HDV	38	89269.000	48785.000	2379900000.000	16523.000	195000.000
HDVPTP	38	74414.000	45393.000	2060500000.000	7112.600	169300.000
EMP	38	1001.600	573.390	328780.000	69.000	2735.000
POP	38	1841.500	824.040	679040.000	399.000	3837.000
COMPL	38	4.447	2.251	5.065	2.000	12.000
INCHH	38	29922.000	5221.200	27261000.000	20452.000	41054.000
R72	38	0.474	0.506	0.256	0.000	1.000
LOADCTP	38	23.546	1.826	3.335	21.264	25.405
ONV	38	31.899	26.756	715.870	1.949	125.630
STOPSM	38	13.421	4.506	20.304	5.000	21.000
USTOPV	38	0.526	0.272	0.074	0.047	1.215
LFTV	38	0.036	0.034	0.001	0.000	0.130
EVENTV	38	0.015	0.012	0.000	0.000	0.054
PTDV	38	0.223	0.030	0.001	0.168	0.251
MPHV	38	27.369	19.234	369.940	9.812	93.764

### Cross-town: Evening

Name	N	Mean	Std. Dev.	Var.	Min.	Max
ONM	38	4.943	3.267	10.676	0.321	15.453
HWSM	38	823.860	66.172	4378.700	716.980	894.970
DDV	38	44044.000	26313.000	692390000.000	7772.300	134390.000
DDVPTP	38	34030.000	17165.000	294640000.000	4408.900	62283.000
POP	38	1841.500	824.040	679040.000	399.000	3837.000
EMP	38	1001.600	573.390	328780.000	69.000	2735.000
COMPL	38	4.447	2.251	5.065	2.000	12.000
INCHH	38	29922.000	5221.200	27261000.000	20452.000	41054.000
R72	38	0.474	0.506	0.256	0.000	1.000
LOADCTP	38	16.558	4.646	21.584	12.045	23.099
ONV	38	14.261	11.588	134.280	0.383	50.554
STOPSM	38	13.395	4.064	16.516	7.000	21.000
USTOPV	38	0.458	0.240	0.058	0.074	1.064
LIFTV	38	0.025	0.039	0.002	0.000	0.212
EVENTV	38	0.009	0.009	0.000	0.000	0.036
PTDV	38	0.144	0.076	0.006	0.037	0.223
MPHV	38	54.554	75.459	5694.100	13.707	368.470

## References

- Abkowitz, M. D. (1978). Transit service reliability. Cambridge, MA: USDOT Transportation Systems Center and Multisystems, Inc. (NTIS No. UMTA/MA-06-0049-78-1).
- Abkowitz, M. D., & Engelstein, I. (1983). Factors affecting **running** time on transit routes. Transportation Research, (2), 107-113.
- Abkowitz, M. D., & Engelstein, I. (1984). Methods for maintaining transit service regularity. Transportation Research Record, 961, 1-8.
- Abkowitz, M. D., Eiger, A., & Engelstein, I. (1986). Optimal headway variation on transit routes. Journal of Advanced Transportation, 20 (1), 73-88.
- Abkowitz, M. D., & Tozzi, J. (1987). Research contributions to managing transit **service** reliability. Journal of Advanced Transportation, 21 (1), 47-65.
- Algers, S., Hanson, S., & Tegner, G. (1975). Role of waiting time, comfort, and convenience in modal choice for work trip. Transportation Research Record, 534, 38-51.
- Allen, W. G., DiCesare, F. (1978). Transit service evaluation: Preliminary identification of variables characterizing level of service. Transportation Research Record, 606, 41-47.
- Bates, J. W. (1986). Definition of practices for bus transit on-time performance: Preliminary study. Transportation Research Circular, 300, 1-5.
- Bowman, L. A., & Tumquist, M. A. (1981). Service frequency, schedule reliability and passenger wait times at transit stops. Transportation Research, 15A, 465-471.
- Furth, P. G. (2000). TCRP Synthesis 34: Data analysis for bus planning and monitoring. Transportation Research Board, National Research Council. Washington DC: National Academy Press.
- Hartgen, D., & Homer, M. W. (1997). A route-level transit ridership forecasting model for Lane Transit District: Eugene, Oregon (Report No. 170). Charlotte, NC: Center for Interdisciplinary Transportation Studies.
- Henderson, G., Adkins, H., & Kwong, P. (1990). Toward a passenger-oriented model of subway performance. Transportation Research Record, 1266, 221-228.
- Homwitz, A. J., & Metzger, D. N. (1985). Implementation of service-area concepts in single route ridership forecasting. Transportation Research Record, 1037, 31-39.
- Kemp, M. A. (1981). A simultaneous equations analysis of route demand, supply, and its application to the San Diego bus system (Report No. 1470-2). Washington DC: The Urban Institute
- Kyte, M., Stoner, J., & Cryer, J. (1988). A time-series analysis of public transit ridership in Portland, Oregon, 1971-1982. Transportation Research, 22A, 345-359.
- Levinson, H. S. (1991). Supervision strategies for improved reliability of bus routes. NCTRP Synthesis of Transit Practice 15. Washington, DC: Transportation Research Board.
- Levinson, H. S., & Brown-West, O. (1984). Estimating bus ridership. Transportation Research Record, 915, 8-12.
- Multisystems, Inc. (1982). Route-level demand models: A review (USDOT Publication No. DOT-1-82-6). Washington DC: U.S. Department of Transportation.

- Nakanishi, Y. J. (1997). Bus performance indicators: On-time performance and service regularity. Transportation Research Record, 1571, 3-13.
- Oliver, A. M. (1971). The design and analysis of bus running times and regularity. London: London Transport.
- Peng, Z., & Dueker, K. J. (1995). Spatial data integration in route-level transit demand modeling. URISA Journal, 7(1), 26-37.
- Peng, Z., & Dueker, K. J. (1994). A GIS at for route-level transit demand modeling. In D. D. Moyer (Ed.), Proceedings of the 1994 Geographic Systems for Transportation (GIS-T) Symposium, 415-433.
- Peng, J. (1994). A simultaneous route-level transit demand model: Demand, supply, and inter-route relationships. Unpublished doctoral dissertation, Portland State University, Portland, OR.
- Sterman, B. P., & Schofer, J. L. (1976). Factors affecting reliability of urban bus services. Transportation Engineering Journal, 104, 147-159.
- Stopher, P. R. (1992). Development of a route level transit patronage forecasting method. Transportation, 19, 201-220.
- Strathman, J. G., Dueker, K. J., & Peng, Z. (1997). Issues in the design of a stop-level transit patronage model. (Report No. PR102). Portland, OR: Portland State University, Center for Urban Studies.
- Strathman, J. G., & Hopper, J. R. (1993). Empirical analysis of bus transit on-time performance. Transportation Research, 27A (2), 93-100.
- Tisato, P. (1998). Service unreliability and bus subsidy. Transportation Research, 32A (6), 423-436.
- Turnquist, M. A. (1978). A model for investigating the effects of service frequency and reliability on bus passenger waiting times. Transportation Research Record, 663, 70-73.
- Turnquist, M. A. (1982). Strategies for improving bus transit service reliability. Evanston, IL: Northwestern University. (NTIS Report No. DOT/RSPA/DPB-50-81-27). Washington, DC: USDOT, Research and Special Programs Administration.
- Welding, P. I. (1957). The instability of close interval service. Operational Research Quarterly, 8, 133-148.
- Woodhull, J. (1987). Issues in on-time performance of bus systems. Unpublished manuscript. Los Angeles, CA: Southern California Rapid Transit District.